

PRODUCT SUBMITTAL

DRESSER Style 128 Flange Adapter

Style 128 Materials of Construction

Follower: AISI C1012 or ASME SA36
 (Ductile Iron or Malleable Iron for 1/2" thru 1-1/2")
Middle Ring/Flange: ASTM A513, ASTM A635 or ASME
 A675 GR60
Bolts: AWWA C 111/ANSI A21.11
Gaskets: Grade 27 BUNA-S as Standard
Coating: Fusion-Bonded Epoxy; Optional RED-D Shopcoat

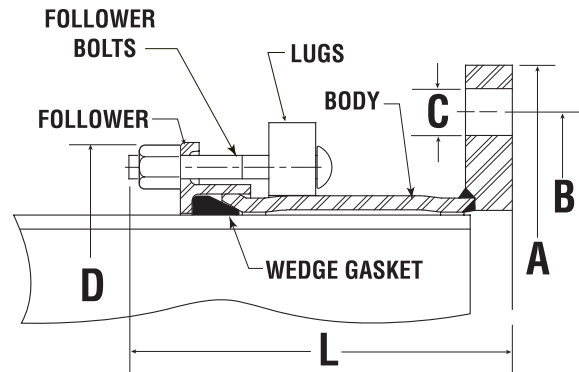

Style 128 Specifications for Steel Pipe Sizes

Nominal Size (Steel)	Outside Diameter (Inches)	Body Thickness X Length (in)	Follower End Bolts Number Diam. & Length	Overall Flange Diameter (A)	Bolt Circle Diameter (B)	No. of Bolt Holes x Diameter (C)	Overall Follower Diameter (D)	Overall Length (L)	Approx. Shipping Weight (Lbs)
2	2-3/8	.156 x 7	3-5/8 x 4	6	4-3/4	4 x 3/4"	6-1/4	8-5/8	14
3	3-1/2	.156 x 7	4-5/8 x 4	7-1/2	6	4 x 3/4"	7-3/8	8-13/16	19
4	4-1/2	.188 x 7	4-5/8 x 4	9	7-1/2	8 x 3/4"	8-3/4	8-13/16	25
5	5-9/16	1/4 x 7	4-5/8 x 4	10	8-1/2	8 x 7/8"	9-5/8	9-9/16	30
6	6-5/8	1/4 x 7	6-5/8 x 4	11	9-1/2	8 x 7/8"	10-1/2	9-1/16	38
8	8-5/8	1/4 x 7	6-5/8 x 4	13-1/2	11-3/4	8 x 7/8"	12-7/16	9-1/16	52
10	10-3/4	1/4 x 7	8-5/8 x 4	16	14-1/4	12 x 1"	14-5/8	9-3/16	58
12	12-3/4	1/4 x 7	8-5/8 x 4	19	17	12 x 1"	16-3/4	9-11/16	79
	14	1/4 x 7	8-5/8 x 4	21	18-3/4	12 x 1-1/8"	18	9-3/4	89
	16	1/4 x 7	10-5/8 x 4	23-1/2	21-1/4	16 x 1-1/8"	20	9-3/4	103
	18	1/4 x 7	10-5/8 x 4-1/2	25	22-3/4	16 x 1-1/4"	22	9-3/4	112
	20	1/4 x 7	12-5/8 x 4-1/2	27-1/2	25	20 x 1-1/4"	24	9-3/4	127
	24	1/4 x 7	14-5/8 x 4-1/2	32	29-1/2	20 x 1-3/8"	28	10	184
	30	1/4 x 7	16-5/8 x 4-1/2	38.75	36	28 x 1-3/8"	36	12	230

ALL STYLE 128 FLANGE ADAPTERS ARE MADE IN AMERICA



imagination at work

GE Oil & Gas
Dresser Pipeline Solutions**
 41 Fisher Avenue
 Bradford, PA 16701
 p: 814.362.9200
 f: 814.362.9393

2014 General Electric Company
 All Rights Reserved
 **Trademark of General Electric
 Company

FORM GE.128.2014